

IMPORTANT NOTE!

Please refer to F-709 for all general installation and maintenance instructions.

Installation

Griswold Controls assumes no responsibility for damages or injuries resulting from non-compliance with installation instructions or standard good practice when installing, operating, or maintaining the valves, even if not explicitly mentioned in the installation instructions.

1. Unpack the valve from box and check inlet and outlet to make sure it is free of packing material.
2. Clean the lines upstream of the valve particles larger than 1/16" diameter (welding slag, pipe scale & other contaminants). Upstream installation of a 20 mesh strainer is recommended.
3. Do not use boiler additives, chemicals which are petroleum based or contain mineral oil, hydrocarbons, azole compounds or ethylene glycol acetate. Compounds which can be used, with minimum 50% water dilution, are diethylene glycol, ethylene glycol, and propylene glycol. If installing these valves in an addition or retrofitting an existing building, do not assume that the fluid in the existing piping meets these criteria.
4. Flow control valves may be inserted in the pipe line either horizontally or vertically. Valve must be installed with 5 pipe diameters of straight piping upstream and 3 pipe diameters of straight piping downstream.
5. Reducing bushings or flanges may be attached directly to flow control valves. Standard adapters are adequate for installation of flow control valves. Please follow good piping practices, system design, and maintenance as outlined in ASHRAE published standards. For example do not pipe valves after two consecutive elbows.
6. All styles of flow control valves are marked to show the direction of flow. **WARNING:** The flow arrow must point in the direction of flow for proper operation.
7. Do not install valves at pump discharge. Minimum of 8 pipe diameters or 8 feet, whichever is longer, is required before the valve.
8. When pressure testing the system with compressed air do not exceed 100 psi air pressure.
9. Standard threaded flow control valves are tapped with NPT. Seal valves with pipe sealant. Please be advised that using tape on a threaded connection can lead to over tightening and cracks in FNPT components. Torque should not exceed 75 foot/pounds.
10. Use two wrenches. Secure one wrench on the hex pads nearest the joint being tightened while using the second wrench to screw in the threaded end.

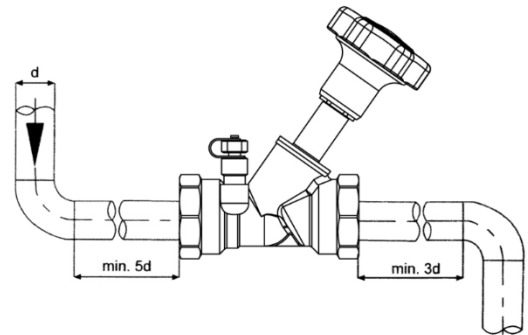

Measurement

The valve is equipped with two test ports. For pressure signal measurements open the cap and insert probe into test ports. Red cap = high pressure, Blue cap = low pressure.

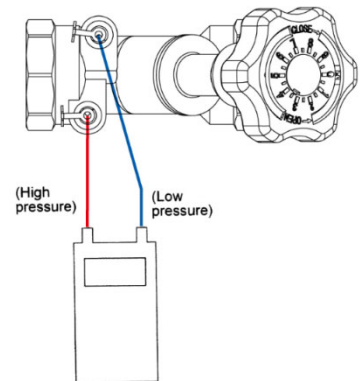

Flow Setting

The valve is shipped in full open position, setting #4.

1. Once the Valve(s) has been installed and the system has been filled and purged, each valve loop must be set to the correct flow setting. Multiple passes are generally required to get the system in balance as the adjustment of each new valve affects the pressure drop (and flow) through the previously adjusted valves.
2. A meter kit can be purchased to take the differential pressure readings. The kit consists of either a 0-100" or 0-300" water column test gauge with the appropriate control valves, hoses and fittings.
3. Rotate the handwheel clockwise to set valve. Closed position has a reading of 0-0.
4. Flow rates are set by adjusting the handwheel until the differential pressure reading across the valve corresponding to the required flowrate (GPM). To calculate the flow signal in Inches H2O the formula should be used: INCHES H2O=(Flow/Vf)²
5. If a reading of zero pressure is present, there may be other valves in the system loop that are closed and will need to be opened to allow flow in this portion of the system. If a reading other than zero is present, use the valve handle to adjust the flow to the correct pressure reading for the unit. Closing the handle will decrease to flow.
6. Repeat this handwheel adjustment for all valves in the system, taking three passes to insure accuracy.
7. Once valve is set use the adjustable Memory Stop with a S3 Allen Key or T15 Torx Bit tool to set the opening limit of the valve to the current setting. The Memory stop will allow the valve to be used (closed) as an isolation valve and then reopened to the pre-set flow rate without the need for reconnection of the meter kit. To set memory stop have center set screw in middle of handwheel fully open. Turn with Allen Key clockwise to tighten set screw.

SIZE	FLOW GPM ⁽¹⁾ @4 FT/SEC	Cv ⁽²⁾							ORIFICE Vf ³	GPM RANGE FOR 1"-100" W.C. ΔP	GPM RANGE FOR 1"-300" W.C. ΔP
		1	1.5	2	2.5	3	3.5	4 ⁴			
1/2"	3.8	0.34	0.53	0.73	0.98	1.47	1.9	2.16	.483	0.48 – 4.9	0.48 – 8.4
3/4"	6.7	0.46	0.68	0.92	1.72	2.44	3.24	3.63	1.010	1.0 – 10.1	1.0 – 17.5
1"	10.8	1.06	1.55	2.05	2.65	3.95	5.57	6.46	1.867	1.9 – 18.7	1.9 – 32.5
1-1/4"	18.7	0.83	1.35	4.07	7.62	10.18	11.68	12.48	3.668	3.7 – 36.5	3.7 – 63.5
1-1/2"	25.4	1.48	2.54	5.78	11.43	16.76	19.42	20.92	5.733	5.7 – 57.5	5.7 – 99.4
2"	41.9	2.25	6.42	13.87	21.39	27.17	30.75	33.64	9.489	9.5 – 95.0	9.5 – 164.5

NOTES

¹ The generally accepted upper limit as recommended by ASHRAE to prevent pipe noise is 4 ft/sec.

² Cv is the GPM of water at 1 PSID drop through the valve at the specific setting. Cv's are used to calculate the permanent pressure drop across valve for pump sizing. PSID=(Flow/Cv)².

³ Vf is used to set valve or for flow measurement. INCHES H₂O=(Flow/Vf)²

⁴ Setting 4 is a full open valve