

# Coil Piping Package Program

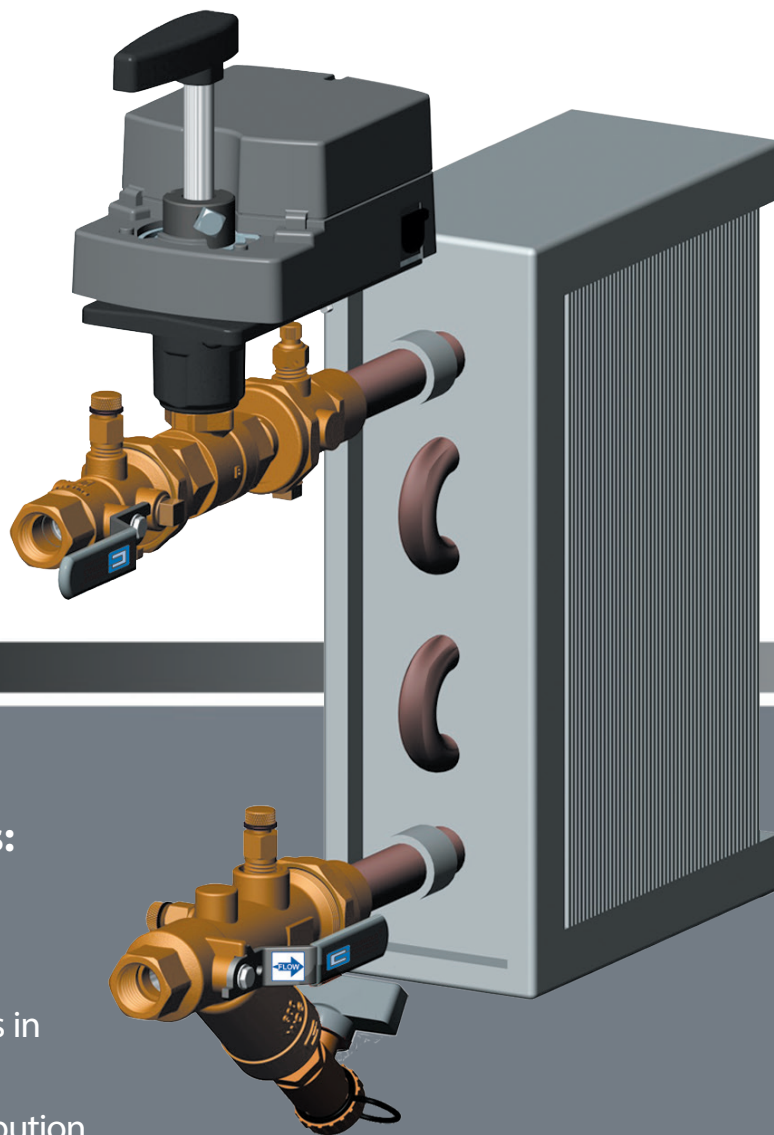

## Recommended Applications:

- Where labor costs need to be decreased
- Where the number of leak points in the system needs to be reduced
- Where hassle-free product distribution at job site is required
- Where the purchase order process needs to be simplified

Absolute Control. **Optimized Efficiency.**

## Features and Benefits

Griswold Controls' coil piping packages are pre-plumbed solutions for specific piping needs, saving you time, labor, and money, and offering the convenience of using only one supplier for all the elements on a system. Coil piping packages make it easy to connect your HVAC system piping to hydronic terminal units such as coils, VAV boxes and AHUs.

- Engineers who specify Griswold Controls' coil piping packages save significant time designing their HVAC systems
- Contractors who use Griswold Controls' preassembled piping packages greatly reduce their labor and material costs.
- Owners save money because they do not have to pay for costly field labor to assemble the components or to check whether every component is plumbed in the correct order, per design.

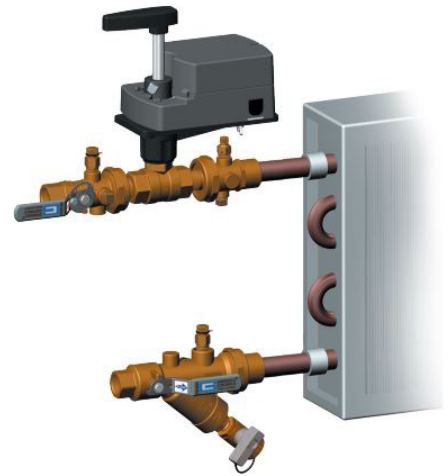

Valves included in standard piping packages are all Next Generation, which contain triple seals and field repairable stems. These Next Generation valves provide resistance to chemical treatments and temperature fluctuations following evening system shutdown, and allow for field servicing without removing the valve.

Piping packages may include, but are not limited to: ball valves, strainers, flow control valves, unions, and 2-way or 3-way temperature control valves. They may also include other components such as air vents, pressure/temperature ports, drain valves, and tees. Piping packages come ready to be hard piped to the system, or with a flexible stainless steel hoses for easy connection to the heating or cooling coil. 1/2" to 2" packages are available with threaded or sweat connections. 2-1/2" to 8" packages are available with flange, weld, or grooved end connections.

Coil piping packages can be designed for virtually any hydronic system. Griswold Controls offers a wide range of standard packages, or we can provide a custom package just for your system.

The parts are placed in their exact required configuration, labeled or tagged, boxed and foam-packed for added protection and shipped to your door. Standard packages up to 2" ship direct to your job site within 48 hours, preassembled and ready to install!

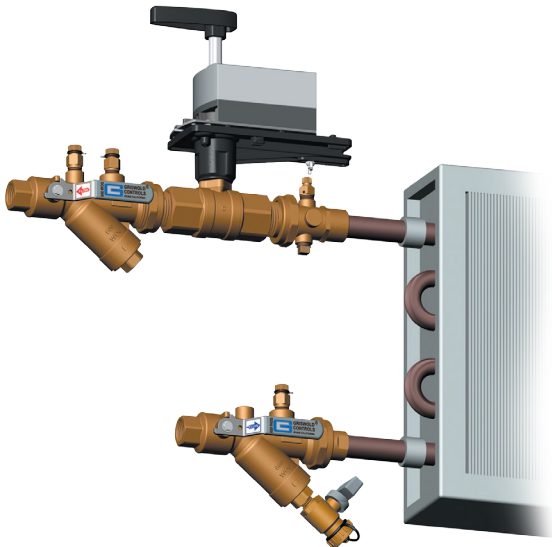

- **Wide Selection of Hydronic Components:** Ball valves, strainers, flow control valves and unions all make it easy to connect HVAC tees and other hydronic components
- **Connections:** End connections are available to match all piping systems
- **2-way or 3-way Temperature Control Valves:** Temperature control valves and actuators are compatible with any system. Griswold Controls Automizer™ and Unimizer™ temperature control valves can be used, providing the shortest lead times. If preferred, however, any other manufacturer's valve can be supplied and Griswold Controls will install it.
- **Factory Assembled Piping Packages:** Components are assembled according to customer specifications by highly trained personnel, allowing piping packages to be designed exactly as required.
- **Simplified Shipping:** Packages are labeled and tagged by location and then vacuum wrapped for easy distribution at job site, or they can be shipped loose.
- **Sizes 1/2" thru 8":** Sized to fit all terminal units, such as fan coils, heat pumps, unit ventilators, AHUs and VAV boxes

Griswold Controls Representative



2803 Barranca Parkway • Irvine CA 92606 | Phone 800 838 0858 • Fax 800 543 8662

E-mail [info@griswoldcontrols.com](mailto:info@griswoldcontrols.com) | [www.griswoldcontrols.com](http://www.griswoldcontrols.com)



9/15  
F-5366C