

The BTU Meter measures flowrate, Delta T, and calculates energy usage.

*Non-shaded Components = BTU Meter*

*Shaded Components = System Components*

**GRISWOLD EPIC CONTROLLER SPECIFICATIONS**

**Supply Voltage:** 24V AC/DC  
**Housing Insulation:** IP 54 including upside down mounting  
**Housing Material:** UL94 V0-rated plastic

**TEMPERATURE SENSOR SPECIFICATIONS**

**Supply Voltage:** 24V DC  
**Media Temperature:** 32° to 212°F  
**Connection:** 1/4" NPT  
**Housing Material:** UL94 V0-rated plastic  
**Signal Output:** 0-5 V (3-wire)  
**Electrical Connection:** Directly Outlet Cable IP67  
**Probe Length:** 50 mm

**TRANSDUCER SPECIFICATIONS**

**Accuracy RSS:** ±0.5% FS  
**Non-Linearity, BFSL** ±0.20% FS  
**Hysteresis** 0.5% FS  
**Non-Repeatability** ±0.05% FS  
**Connection:** 1/4" NPT  
**Thermal Effects °F (°C)** Compensated 14 to 140 (-10 to 60)  
**Zero Shift %FS/°F(%FS/°C)** < ±0.02 (<±0.04)  
**Span Shift %FS/°F(%FS/°C)** < ±0.02 (<±0.04)  
**Line Pressure Effect** Zero shift approx. ±0.004% FS/psig line pressure  
**Resolution** Infinite, limited only by output noise level (0.02% FS)  
**Static Acceleration Effect** 2% FS/g (most sensitive axis)  
**Natural Frequency** > 500 Hz (gaseous media)  
**Response Time** 30 to 50 milliseconds  
**Maximum Working Pres:** 250 psig  
**Circuit:** 2-wire  
**Output at Zero Pressure:** 4mA (1V with filter)  
**Output at Full Range:** 20mA (5V with filter)  
**Pressure<sup>1</sup>:** 0-16 Bar (0-401.8"WC)

**NOTES**

<sup>1</sup> Calibrated at factory at 24Vdc.

**Full Scale Output:** 16mA (4V with filter)  
**External Load:** 0 to 1000 Ω  
**Minimum Supply Voltage:** 12vDC + 0.02 x (Resistance of receiver plus line)  
**Maximum Supply Voltage:** 30vDC + 0.004 x (Resistance of receiver plus line)

**VENTURI METERING STATION SPECIFICATIONS**

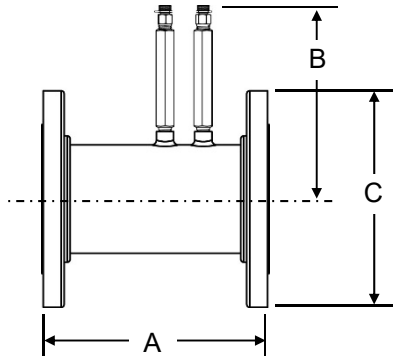

**PSI/Temperature Rating:** 240 PSI/250° F  
**Low Loss Venturi:** Carbon Steel with Piezo-Ring to average low signal pickup.  
**Body Material:** Carbon Steel SA-53 Grade B.  
**End Connections:** Steel flanges ANSI B16.5-RF Class 150  
**Installation:** No straight-run is necessary for normal operation.

**DIMENSIONS & WEIGHTS FOR METERING STATION (NOMINAL)**

LINE SIZE	A	B	C	WEIGHT (LBS.)
2-1/2"	6.3	7.3	7.0	17.9
3"	6.8	7.6	7.5	21.9
4"	8.4	8.0	9.0	31.5
5"	10.3	8.6	10.0	40.0
6"	10.8	9.1	11.0	51.7
8"	12.8	10.1	13.5	86.5
10"	16.0	11.2	16.0	130.6
12"	16.8	12.2	19.0	191.1
14"	17.0	12.8	21.0	244.7
16"	18.0	13.8	23.5	300.1
18"	17.3	14.8	25.0	326.5
20"	20.9	14.2	27.5	TBD

All dimensions are for planning purpose only, contact factory for actual measurement at time of order.

**MODEL NUMBER SELECTION**

B
T
U
0

Select a Size: M=2.5", N=3", P=4",  
 Q=5" R=6", S=8", T=10", U=12",  
 V=14", W=16", X=18", Y=20"

Tag: 0=Standard, T=Hanging Tag

**FLOW RATES**

LINE SIZE	MODEL NO.	Cv <sup>2</sup>	GPM RANGE FOR 5"-100" <sup>3</sup> W.C. ΔP (SET W/100" GAUGE)	GPM RANGE FOR 5"-300" W.C. ΔP (SET W/300" GAUGE)
2-1/2"	BTUM	171	19 – 87	19 – 151
3"	BTUN	269	32 - 147	32 – 255
4"	BTUP	580	58 – 260	58 – 451
5"	BTUQ	800	80 – 372	80 – 645
6"	BTUR	1250	140 – 624	140 – 1075
8"	BTUS	2100	260 – 1180	260 – 2045
10"	BTUT	4000	375 – 1610	375 – 2790
12"	BTUU	5700	600 – 2790	600 – 4820
14"	BTUV	7300	775 – 3420	775 – 5940
16"	BTUW	9600	1250 – 5525	1250 – 9575
18"	BTUX	14500	1650 – 7405	1650 – 12830
20"	BTUY	26400	2246 – 10071	22460 - 17448

**NOTES**

<sup>2</sup> Cv's are used to calculate permanent pressure drop.  $PSID=(Flow/Cv)^2$ . Consult chart F-4439 for flow measurement.

<sup>3</sup> Not all gages/meters can accurately show a 5" signal. Readability is dependent on quality of the meter. Digital gages can read below 1".