

QuickSet Shown

SPECIFICATIONS:

PSI/Temperature Rating

Metering Station:

240 PSI/275° F

QuickSet:

200 PSI (14"-18": 150 PSI) /275° F

Low Loss Venturi:

Carbon Steel with Piezo-Ring to average low signal pickup.

Body Material:

Carbon Steel SA-53 Grade B.

Butterfly Valve¹:

Bronze disk, S.S. Stem

End Connections:

Steel flanges ANSI B16.5 CL 150

Body Tappings:

1/4" NPT with Brass P/T test valves

Optional Accessory Ports:

Port 1: 1/4" for Air Vent

Port 2: 3/4" for Thermowell

Port 3: 1/2" for Drain Valve

Installation:

No straight-run pipe is necessary for normal operation. Consult chart (F-4439) for exact Flow Constant and Permanent Pressure Drop calculations.

QuickSet (2-1/2"-6")

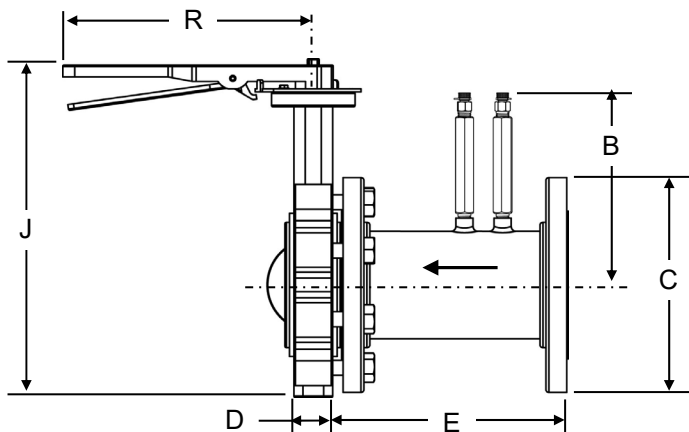

QuickSet (8"-18")

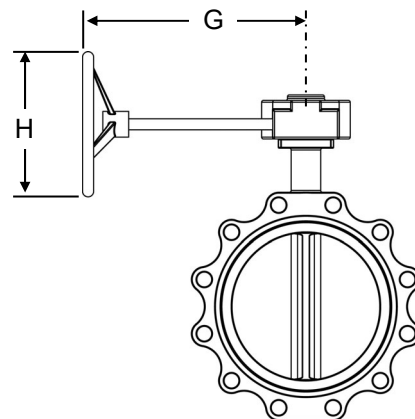

DIMENSIONS & WEIGHTS FOR QUICKSET (NOMINAL)

All dimensions are for planning purposes only and may change without notice.

| LINE SIZE | B | C | D | E | G | H | J | R | WEIGHT (LBS.) | |
|-----------|------|------|-----|------|------|------|------|------|---------------|--------------|
| | | | | | | | | | W/HANDLE | W/GEAR WHEEL |
| 2-1/2" | 7.3 | 7.0 | 1.8 | 6.3 | N/A | N/A | 11.6 | 10.5 | 32 | N/A |
| 3" | 7.6 | 7.5 | 1.8 | 6.8 | N/A | N/A | 12.1 | 10.5 | 35 | N/A |
| 4" | 8.0 | 9.0 | 2.0 | 8.4 | N/A | N/A | 13.6 | 10.5 | 52 | N/A |
| 5" | 8.6 | 10.0 | 2.1 | 10.3 | N/A | N/A | 14.6 | 10.5 | 77 | N/A |
| 6" | 9.1 | 11.0 | 2.3 | 11.8 | N/A | N/A | 15.6 | 10.5 | 91 | N/A |
| 8" | 10.1 | 13.5 | 2.4 | 15.3 | N/A | 12.0 | 18.9 | N/A | N/A | 170 |
| 10" | 11.2 | 16.0 | 2.6 | 18.3 | 9.5 | 12.0 | 21.3 | N/A | N/A | 258 |
| 12" | 12.2 | 19.0 | 3.0 | 21.8 | 9.5 | 12.0 | 24.6 | N/A | N/A | 362 |
| 14" | 12.8 | 21.0 | 3.0 | 24.3 | 9.5 | 12.0 | 26.8 | N/A | N/A | 464 |
| 16" | 13.8 | 23.5 | 4.0 | 27.8 | 15.0 | 16.0 | 30.0 | N/A | N/A | 630 |
| 18" | 14.8 | 25.0 | 4.5 | 32.0 | 15.0 | 16.0 | 31.6 | N/A | N/A | 743 |

NOTES

¹ Butterfly valve is standard on QuickSet only.

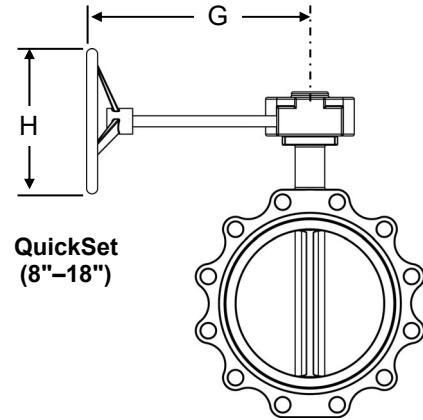
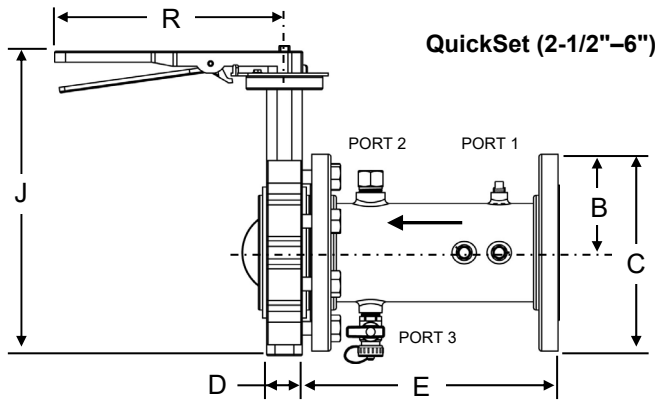

DIMENSIONS & WEIGHTS FOR QUICKSET WITH ACCESSORY PORTS (NOMINAL)

All dimensions are for planning purposes only and may change without notice.

| LINE SIZE | B | C | D | E | G | H | J | R HANDLE | WEIGHT (LBS.) | |
|-----------|-------|-------|------|-------|------|------|-------|----------|---------------|--------------|
| | | | | | | | | | W/ HANDLE | W/GEAR WHEEL |
| 2-1/2" | 7.19 | 7.00 | 1.75 | 10.00 | N/A | N/A | 11.63 | 10.5 | 34 | N/A |
| 3" | 7.50 | 7.50 | 1.75 | 10.50 | N/A | N/A | 12.13 | 10.5 | 38 | N/A |
| 4" | 8.00 | 9.00 | 2.00 | 11.38 | N/A | N/A | 13.63 | 10.5 | 56 | N/A |
| 5" | 8.53 | 10.00 | 2.13 | 13.13 | N/A | N/A | 14.63 | 10.5 | 65 | N/A |
| 6" | 9.06 | 11.00 | 2.25 | 13.63 | N/A | N/A | 15.63 | 10.5 | 95 | N/A |
| 8" | 10.06 | 13.50 | 2.38 | 17.00 | 9.5 | 12.0 | 18.88 | N/A | N/A | 176 |
| 10" | 11.13 | 16.00 | 2.88 | 20.88 | 9.5 | 12.0 | 21.25 | N/A | N/A | 252 |
| 12" | 12.13 | 19.00 | 3.00 | 23.50 | 9.5 | 12.0 | 24.63 | N/A | N/A | 300 |
| 14" | 12.75 | 21.00 | 3.00 | 25.88 | 9.5 | 12.0 | 26.75 | N/A | N/A | 395 |
| 16" | 13.75 | 23.50 | 4.00 | 29.25 | 15.0 | 16.0 | 30.00 | N/A | N/A | 505 |
| 18" | 14.75 | 25.00 | 4.25 | 33.63 | 15.0 | 16.0 | 31.63 | N/A | N/A | 645 |

DIMENSIONS & WEIGHTS FOR METERING STATIONS (NOMINAL)

All dimensions are for planning purposes only and may change without notice.

| LINE SIZE | A | B | C | WEIGHT (LBS.) |
|-----------|------|------|------|---------------|
| 2-1/2" | 6.3 | 7.3 | 7.0 | 18 |
| 3" | 6.8 | 7.6 | 7.5 | 22 |
| 4" | 8.4 | 8.0 | 9.0 | 32 |
| 5" | 10.3 | 8.6 | 10.0 | 45 |
| 6" | 10.8 | 9.1 | 11.0 | 54 |
| 8" | 12.8 | 10.1 | 13.5 | 90 |
| 10" | 16.0 | 11.2 | 16.0 | 148 |
| 12" | 16.8 | 12.2 | 19.0 | 204 |
| 14" | 17.0 | 12.8 | 21.0 | 244 |
| 16" | 18.0 | 13.8 | 23.5 | 301 |
| 18" | 17.3 | 14.8 | 25.0 | 325 |
| 20" | 20.9 | 14.2 | 27.5 | TBD |

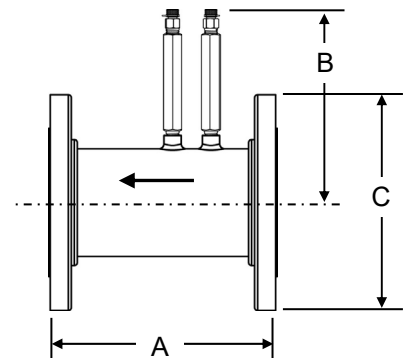

DIMENSIONS & WEIGHTS FOR METERING STATIONS WITH ACCESSORY PORTS (NOMINAL)

All dimensions are for planning purposes only and may change without notice.

| LINE SIZE | A | B | C | WEIGHT (LBS.) |
|-----------|-------|-------|-------|---------------|
| 2-1/2" | 10.00 | 7.19 | 7.00 | 21 |
| 3" | 10.50 | 7.50 | 7.50 | 25 |
| 4" | 11.38 | 8.00 | 9.00 | 36 |
| 5" | 13.13 | 8.53 | 10.00 | 45 |
| 6" | 13.63 | 9.06 | 11.00 | 59 |
| 8" | 17.00 | 10.06 | 13.50 | 101 |
| 10" | 19.88 | 11.13 | 16.00 | 145 |
| 12" | 22.13 | 12.13 | 19.00 | 229 |
| 14" | 24.13 | 12.75 | 21.00 | 285 |
| 16" | 27.00 | 13.75 | 23.50 | 355 |
| 18" | 30.75 | 14.75 | 25.00 | 415 |

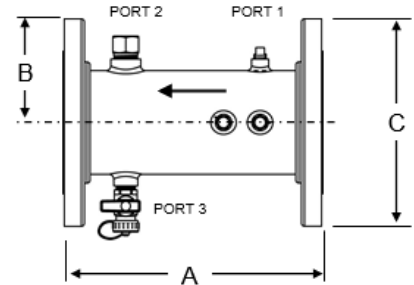

FLOW RATES (+/-1%²)

| LINE SIZE | Cv Metering Station ³ | Cv QuickSet ³ | Cv Metering Station with Accessory ³ | Cv QuickSet with Accessory ³ | GPM RANGE FOR 5-100" ⁴ W.C. ΔP (SET W/100" GAUGE) | GPM RANGE FOR 5-300" W.C. ΔP (SET W/300" GAUGE) | Turn Down Ratio |
|------------------|----------------------------------|--------------------------|---|---|--|---|-----------------|
| 2-1/2" | 171 | 135 | 169 | 134 | 19 – 87 | 19 – 151 | 7.9 |
| 3" | 269 | 201 | 242 | 189 | 32 – 147 | 32 – 255 | 7.9 |
| 4" | 580 | 417 | 506 | 387 | 58 – 260 | 58 – 451 | 7.8 |
| 5" | 800 | 630 | 680 | 566 | 80 – 372 | 80 – 645 | 8.1 |
| 6" | 1250 | 980 | 900 | 782 | 140 – 624 | 140 – 1075 | 7.7 |
| 8" | 2100 | 1745 | 1800 | 1561 | 260 – 1180 | 260 – 2045 | 7.8 |
| 10" | 4000 | 3201 | 3900 | 3149 | 375 – 1610 | 375 – 2790 | 7.4 |
| 12" | 5700 | 4690 | 4930 | 4232 | 600 – 2790 | 600 – 4820 | 8.0 |
| 14" | 7300 | 6225 | 6800 | 5906 | 775 – 3420 | 775 – 5940 | 7.7 |
| 16" | 9600 | 8283 | 8900 | 7821 | 1250 – 5525 | 1250 – 9575 | 7.7 |
| 18" | 14500 | 12057 | 13000 | 11153 | 1650 – 7405 | 1650 – 12830 | 7.8 |
| 20" ⁵ | 26400 | 19950 | N/A | N/A | 2246 – 10071 | 22460 – 17448 | 7.7 |

MODEL NUMBER SELECTION

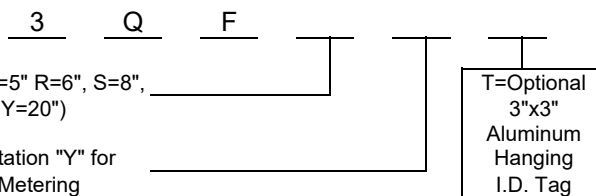

Select a Size (M=2.5", N=3", P=4", Q=5" R=6", S=8", T=10", U=12", V=14", W=16", X=18", Y=20")

Select Valve Style ("0" for Metering Station "Y" for QuickSet with Butterfly Valve, "A" for Metering Station with Accessory Port "B" for QuickSet with Accessory Port with Butterfly Valve)

NOTES

² Accuracy is for venturi portion of valve only. Pressure readability is dependent on accuracy of gauge and system pressure stability.
³ Cv's are used to calculate permanent pressure drop. PSID=(Flow/Cv)². Consult chart F-4439 Smart Phone app for flow measurement.
⁴ Not all gages/meters can accurately show a 5" signal. Readability is dependent on quality of the meter. Digital gages can read below 1".
⁵ 20" is only available as a Metering Station.

This specification © 2021 Griswold Controls

1700 Barranca Parkway, Irvine, CA 92606
 (949) 559-6000 Fax (949) 559-6088
 www.GriswoldControls.com