



**SPECIFICATIONS**

**PSI / Temperature Rating:** 265 PSIG / 400° F (See P/T Limit Chart)  
**Cartridge:** AISI Type 304 stainless steel  
 AISI Type 17-7 PH stainless steel spring  
**Body Material:** 316 Stainless Steel  
**Seals:** Viton O-Rings  
**Body Tappings:** 1/4" NPT with (3) hand tight SS plugs  
 (Optional (2) SS PTs with EPDM core)<sup>1</sup>  
**Flanges:** Flanges are compatible with ANSI B  
 16.5-1968 150 lb. Steel flanges

**DIMENSIONS & WEIGHTS (NOMINAL)**

All dimensions are for planning purposes only and may change without notice.

SIZE	MODEL NO.	X (LENGTH)	Y (WIDTH)	WEIGHT (LBS.)
1-1/2"	4S_	7.0	5.0	10
2"		7.0	6.0	12
3"		7.3	7.5	43
4"		18.4	9.0	77
6"		13.8	11.0	88
8"		18.1	13.5	158
10"		18.2	16.0	200
12"		29.3	19.0	330

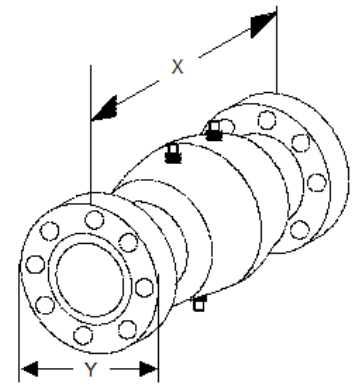

**FLOW RATES (+/-5%)**

SIZE	MODEL NO.	HEAD LOSS IN FEET <sup>2</sup>	PSID RANGE	GPM
1-1/2", 2"	4S_1	3.5	1.5-14	3.0, 3.33, 4.00, 4.67, 5.33, 6.00, 6.67, 7.33, 8.00, 8.67, 9.33, 10.00, 10.67, 11.33, 12.00, 12.67, 13.33, 14.00, 14.67
	4S_2	7.4	3.2-32	4.5, 5.0, 6.0, 7.0, 8.0, 9.0, 10.0, 11.0, 12.0, 13.0, 14.0, 15.0, 16.0, 17.0, 18.0, 19.0, 20.0, 21.0, 22.0
	4S_4	13.4	5.8-57	6.00, 6.67, 8.00, 9.33, 10.67, 12.00, 13.33, 14.67, 16.00, 17.33, 18.67, 20.00, 21.33, 22.67, 24.00, 25.33, 26.67, 28.00, 29.33
	4S_8	30.0	13-128	9.0, 10.0, 12.0, 14.0, 16.0, 18.0, 20.0, 22.0, 24.0, 26.0, 28.0, 30.0, 32.0, 34.0, 36.0, 38.0, 40.0, 42.0, 44.0

TYPE OF CARTRIDGE:		STANDARD FLOW				
LINE SIZE	MODEL NO.	NOMINAL CONTROL RANGE (PSID)	1.5-20	3.2-32	5.8-57	13-128
		HEAD LOSS IN FEET <sup>2</sup>	3.0	7.4	13.4	30.0
		MIN. AVAILABLE GPM	14	17.5	23.33	35
		GPM INCREMENTS	2.0	2.5	3.33	5.0
3	4SF	Maximum GPM	60	75	100	150
4	4SG	Maximum GPM	180	225	300	450
6	4SH	Maximum GPM	180	225	300	450
8	4SJ	Maximum GPM	360	450	600	900
10	4SK	Maximum GPM	480	600	800	1,200
12	4SL	Maximum GPM	840	1,050	1,400	2,100

**NOTES**

<sup>1</sup> SS PT option available on 1-1/2"-3" valves only. Thread sealant applied during installation to PTs and plug.

<sup>2</sup> Head Loss in Feet is provided for pump head calculations. (1 PSI = 2.307 Feet of Water)

TYPE OF CARTRIDGE:		STANDARD FLOW HIGH CAPACITY		
LINE SIZE	MODEL NO.	NOMINAL CONTROL RANGE (PSID)	4-20	8-32
		MAX. PRES. DIFF. (PSI)	20	32
		HEAD LOSS IN FEET	9.2	18.4
		GPM INCREMENTS	20.0	25.0
3	4SF_	Minimum GPM	90	110
		Maximum GPM	130	160

TYPE OF CARTRIDGE:		HI - FLOW				
LINE SIZE	MODEL NO.	NOMINAL CONTROL RANGE (PSID)	3-18 (LOW INCREMENTS)	3-18 (HIGH INCREMENTS)	5-32 (LOW INCREMENTS)	5-32 (HIGH INCREMENTS)
		MAX. PRES. DIFF. (PSI)	18	18	32	32
		HEAD LOSS IN FEET	5.8	5.8	11.5	11.5
		GPM INCREMENTS	2.0	N/A	2.5	N/A
4	4SG_	Minimum GPM	100	300	135	535, 560, 600
		Maximum GPM	260		475	
6	4SH_	Minimum GPM	100	300	135	535, 560, 600
		Maximum GPM	260		475	
8	4SJ_	Minimum GPM	100	600	135	1135, 1160, 1200
		Maximum GPM	560		1,075	
10	4SK_	Minimum GPM	100	800	135	1535, 1560, 1600
		Maximum GPM	760		1,475	
12	4SL_	Minimum GPM	100	1,400	135	2735, 2760, 2800
		Maximum GPM	1,360		2,675	

**MODEL NUMBER SELECTION<sup>3</sup>**

4
S

Insert "D" for 1-1/2", "E" for 2", "F" for 3",  
 "G" for 4", "H" for 6", "J" for 8", "K" for 10", and  
 "L" for 12"

Select a PSID control range (1=1.5-14 or 4-20,  
 2=3.2-32 or 8-32, 4=5.8-57, 8=13-128)

Select Port (0=SS Plugs, 1=Two SS PT and Plug)

**PRESSURE & TEMPERATURE LIMITS**

This Pressure vs. Temperature chart can be used to determine if specific Griswold Constant Flow Regulator models and mountings are compatible with your application.

Please contact your local Representative or Griswold Controls for pressure and temperature requirements above and below the limits shown.

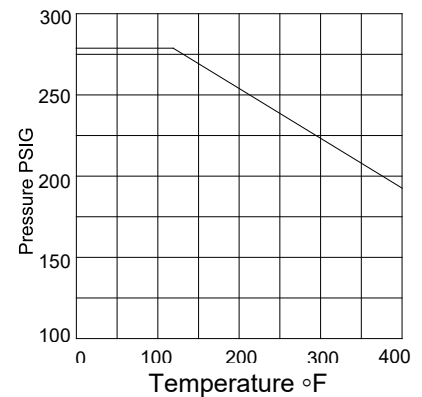

**NOTES**

<sup>3</sup> Model no. and flow rate are indicated on label affixed to body.